



CF 101

Counter Top Continuous Freezer

1 HP Refrigeration System
Self-Contained, Air Cooled
3 Gallon Hopper
230VAC/60HZ/1 or 3Ø

Produces Frozen Custard, Gelato and other Frozen Desserts

Featuring Ross Quick-Freeze™ Technology



Features

- Quick-Freeze™ Technology
- Counter top model
- “Hold product” mode

Advantages

- Minimizes size of ice crystals
- Minimum counter space needed
- Ability to suspend production

Benefits

- Smoothest finished product
- Easy to Install
- Match production to demand

The Secret's in the Barrel! 



Made in the U.S. A.

Model CF-101 Counter Top Continuous Freezer

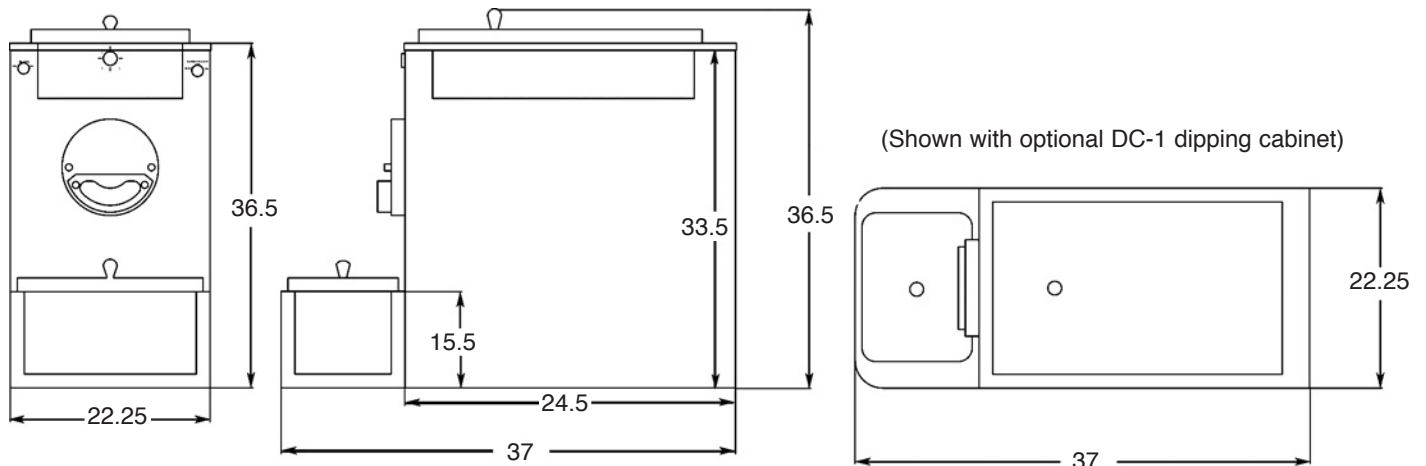

DIMENSIONS

COUNTER TOP CONTINUOUS FREEZER	in.	cm.
Width	22.25	51
Depth	37	94
Height Overall.....	36.5	93

WEIGHTS

COUNTER TOP CONTINUOUS FREEZER	lbs.	kgs.
Air	350	158.8
Air (Crated).....	400	181.4

ELECTRICAL

Voltage/Hz/Phase	Breaker Size	Pole (P) Wire (W)
208-230/60/1 Air	20A	3P 3W
208-230/60/3 Air (special order)	20A	3P 4W

SPECIFICATIONS

BEATER MOTOR:

(1) 1½ HP motor

REFRIGERATION SYSTEM:

- (1) 1 HP compressor, R-404A Refrigerant, 3600 BTU/H
- Separate hopper refrigeration, R-404A Refrigerant
- Self Contained
- Air flow at rear of unit - install at least 6" from obstruction or wall

OPTIONS:

- Dipping cabinet (shown in photo and drawing), Model DC-1, 0.2 HP compressor, R-404A Refrigerant 750 BTU/H 115V/60HZ/1Ø/5A

HOPPER CAPACITY:

3 gallons of liquid mix

Additional Features and Benefits

- Easy to clean to ensure sanitary operation
- Refrigerated hopper to increase production



www.rossmanufacturing.com
 1-888-339-4429 • 906-786-4894 • Fax 906-786-7928
 3707 19th Avenue North, Escanaba, Michigan 49829